



Icemaster G20.1 – Glycol Chiller Instruction manual

KL16049



KegLand Distribution PTY LTD

www.KegLand.com.au



 **WARNING** 

IF THE GLYCOL CHILLER HAS JUST BEEN MOVED DO NOT TURN ON UNLESS THE GLYCOL CHILLER HAS BEEN STANDING UPRIGHT FOR 24 HOURS. FAILURE TO DO SO WILL VOID WARRANTY. STAND THE GLYCOL CHILLER IN THE UPRIGHT POSITION FOR 24 HOURS BEFORE PLUGGING INTO THE MAINS SOCKET

 **WARNING** 

ENSURE THAT THERE IS ALWAYS ATLEAST 100mm OF CLEARANCE ON EACH SIDE OF THE GLYCOL CHILLER TO ALLOW ADEQUATE AIRFLOW. NOT ALLOWING ADEQUATE VENTILATION WILL REDUCE PERFORMANCE, INCREASE POWER CONSUMPTION AND VOID WARRANTY

 **WARNING** 

THE GLYCOL CHILLER IS NOT INTENDED FOR COOLING WORT FROM BOILING TEMPERATURES. USING THE CHILLER TO COOL FROM BOILING TEMPERATURES COULD OVERLOAD THE COMPRESSOR AND VOID WARRANTY

 **WARNING** 

DO NOT RUN THE PUMPS DRY. ENSURE THE PUMPS ARE ALWAYS SUBMERGED WHEN IN OPERATION. RUNNING DRY CAN DAMAGE THE PUMPS



INITIAL STARTUP AND TESTING

Important

Let the glycol chiller sit for at least 24 hours after delivery or after sitting on its side before turning the unit on.

Whenever the glycol chiller is operating and cooling the reservoir the pumps should be operating to keep the liquid in the reservoir agitated and avoid ice formation.

Firstly, attach the sight glass to your G20 by firmly pushing the two 3/8" duotight tee pieces ([KL07023](#)) onto the push fit tubes on the front of the G20 as shown to the right. Confirm this is held in place securely by pulling on the duotight fittings and ensuring they are locked in place.

Then, perform a leak test and cooling test on your system to ensure that all connections are water tight, the pumps are operational and the glycol chiller is chilling the reservoir correctly.

Testing the system

1. With the G20 unplugged fill the reservoir with water until it reaches the top of the sight glass.
2. Look for any signs of leaks around the exterior of the G20.
3. Attach 10mm ID silicone tube ([KL18142](#)) to the two OUT barbs.
4. Connect each of these silicone tubes to the adjacent IN barbs.



5. Plug the G20 in using the provided IEC cable and turn the red power switch on.
6. Set the temperature on each temperature controller on the front of the G20 to 2°C
 - Hold the 'Up' button for 3 seconds until the number is flashing (this flashing number is your set temperature).
 - Press the 'Down' button to decrease the set temperature and press the 'Up' button to increase the set temperature.





7. Check that each pump is operating correctly
 - This can be determined by looking for water flow through the silicone tubes or by placing the outlet hose into a jug and ensuring that liquid is being pumped out of the hose into the jug.
8. Set the temperature on the controller on the rear of the G20 above the IEC plug to 2°C.
 - Hold the 'S' button until F1 is displayed.
 - Press 'S' again which will enter temperature adjustment mode.
 - Then hold 'S' and up or down buttons simultaneously to alter the set temperature of the reservoir.
 - Once the desired temperature has been entered, press and release the power key to save the parameter.

NOTE: The full instruction manual for the STC-1000 temperature controller can be found here:
<https://www.kegland.com.au/media/pdf/stc1000%20instructions.pdf>

During this step you can get a rough guide of the cooling factor of the glycol chiller when not under load. To determine this note the starting temperature of the water in the reservoir and then measure how long it takes to drop the temperature to 2°C.

Prior to putting any beer into the fermenter for cooling you should leak test your whole system. This can be done by connecting the silicone tubing from the OUT barb to the cooling coil of the fermenter and then connect the silicone tube from the fermenter to the IN barb on the G20.

Set the temperature on the temperature controller to 2C and test that there are no leaks in the system including into the fermenter itself.

After all testing is complete empty the reservoir by removing the plug on the bottom 3/8" duotight fitting on the nylon sight tube. This can be achieved by removing the blue retaining clip on the duotight fitting and pushing in on the collar as you pull on the plug. After you have drained the reservoir put the plug retaining clip back in place.

The system has now been tested for cooling and leaks and is ready to be used to cool a fermenter.

Filling the reservoir

The G20 can be operated with either just water in the reservoir or both water and glycol to reduce the freezing point of water.

IMPORTANT: If you are only using water in the reservoir and not glycol then do not set the temperature of the reservoir below 2°C.

Fill the reservoir with water to the top of the sight glass, if the reservoir is set at 2°C or an appropriate concentration of glycol solution if dropping the reservoir below 2°C according to the table below. Ensure the cooling coils are submerged. The amount of glycol required to be added to the reservoir depends on the desired set temperature of the reservoir which is dependent on a number of factors including how many fermenters are being cooled, the ambient temperature the fermenters are in and heat ingress etc. Use the table below to determine what percentage of glycol you require.





Glycol Volume %	Freezing Point °C	Specific Gravity at 21°C
0	0.0	1.000
10	-3.3	1.006
20	-7.8	1.015
30	-13.3	1.024

You can measure the glycol percentage using a calibrated refractometer and comparing to the specific gravity at 21°C in the above table.

We would advise running a 20% glycol solution however, if you do not have a jacketed fermenter or have the fermenter in a very warm environment you can run it at a higher glycol concentration. The pumps are not designed to be run with a glycol concentration higher than 30% hence it is not advised to exceed this glycol concentration. Doing so may damage the pumps.

Setup for each fermenter

1. Prior to connecting the G20 to the fermenter ensure that the temperature of the liquid in the fermenter is below 50°C. The G20 is not designed to cool from boiling to 50°C and instead normal tap water should be recirculated through the cooling coils first to drop the temperature of the liquid.
2. Connect a suitable length of silicone tubing for your application to the desired outlet (OUT) port on the G20.
3. Connect the silicone tubing to the cooling coil on your fermenter.
4. Run a length of silicone tubing from the fermenter back into the inlet (IN) adjacent to the outlet chosen on the G20.
5. Insert the temperature probe into the thermowell of the fermenter being controlled.
6. Set the temperature on the temperature controller to the set temperature of fermentation
7. Set the temperature on the temperature controller for the reservoir to -2°C if using glycol. **If you are only using water in the reservoir and not glycol then do not set the temperature of the reservoir to below 2°C.**

When under load such as when cooling a fermenter it can take a longer time than the cooling factor you have measured to cool the reservoir down to the set temperature and this time is dependent on a number of variables including and not limited to:

- Jacketing of the fermenter (jacketed or non-jacketed)
- Number of fermenters being cooled
- Ambient temperature
- Heat ingress

Cooling fermenters at a large distance away from the G20

The G20 is capable of cooling 200L jacketed fermenters. However, if your fermenter is a large distance away from the G20 then the submersible pumps may not be able to handle this increased resistance. Hence, it is suggested for fermenters at a distance that an external pump be used to transfer the glycol to the fermenter.



1. Connect an external pump to an external temperature controller.
2. Remove the retaining clip and 3/8" plug from the bottom duotight fitting on the nylon sight tube. Attach 3/8" EVABarrier tubing ([KL06248](#)) to the duotight fitting and connect this tubing to your external pump.
3. Attach tubing to the outlet of the external pump and attach this tube to the cooling coils on your fermenter.
4. Run tubing from the outlet of the fermenter cooling coils back into the reservoir of the G20
5. Set the temperature on the G20 to -2°C (if using glycol) or to 2°C (if only using water in the reservoir).
6. Insert the temperature probe of the external temperature controller into the thermowell on your fermenter.
7. Set the temperature on your external temperature controller to your desired fermentation temperature. This will cycle the pump on and off to supply cold glycol solution only when the temperature of the fermenter increases above the set fermentation temperature.

For best performance, insulate the glycol lines between the G20 and the fermenter.

Temperature probe removal

The temperature probes for the temperature controllers on the front which control the pumps can be removed if a longer probe is required to reach your fermenter.

To remove the temperature probe simply unplug it from the socket on the G20 and then plug your new probe in.





TEMPERATURE CONTROLLER SET POINT AND PARAMETER ADJUSTMENT

The G20.1 includes temperature controllers on the front of the G20 which controls the switching on and off of the submersible pumps and can also be wired to control an external heating source. To adjust the parameters of the temperature controllers on the front of the G20 follow these steps:

Turn the Temperature Controller On/Off - Hold the “Down” button for 3 seconds

Adjusting the Set Temperature:

1. Hold the ‘Up’ button for 3 seconds until the number is flashing (this flashing number is your set temperature).
2. Press the ‘Down’ button to decrease the set temperature and press the ‘Up’ button to increase the set temperature.

Parameter Adjustment

3. Hold the “Up” and “Down” buttons simultaneously for 3 seconds. The first menu code F0 will appear on the display.
4. Press the “Up” or “Down” buttons to cycle through the parameters F0-F12
5. Press both the “Up” and “Down” buttons simultaneously to alter the parameter which appears on the display.
6. Press the “Up” or “Down” buttons to change the set value of the parameter selected.

If there is no key operation within 5 seconds then the parameter will be set with the displayed value. The parameters which can be modified are outlined below.

Parameter	Function	Range	Default	Units
F0	SetPoint range	-40.0 – 90.0	10.0	°C
F1	Minimum value for SetPoint	-40.0 – F0	-40.0	°C
F2	Maximum value for SetPoint	F0 – 90.0	90.0	°C
F3	Cooling hysteresis	0.1 – 10.0	0.5	°C
F4	Heating hysteresis	0.1 – 10.0	0.5	°C
F5	Temperature probe calibration	-10.0 – 10.0	0	°C
F6	Cooling start delay	1 – 10.0	1	Minute
F7	Cooling start delay after power failure	0 – 300	10	Second
F8	Heating start delay	1 – 10.0	1	Minute
F9	Heating start delay after power failure	0 – 300	10	Second
F10	Maximum temperature before alarm activation	F11 – 99.9	90.0	°C
F11	Minimum temperature before alarm activation	-45.0 – F10	-40.0	°C
F12	Alarm delay	1 – 120	1	Minute



To change any settings on the temperature controller for the reservoir such as temperature hysteresis or calibration refer to this instruction manual

<https://www.kegland.com.au/media/pdf/stc1000%20instructions.pdf>

MAINTENANCE

If the glycol solution has been stored for an extended period of time then it is suggested to replace the solution, despite glycol having antimicrobial properties. To replace the glycol empty the reservoir using the drainage port and then refill with the required concentration of glycol using a refractometer to confirm the concentration.



HEATING RELAY INSTRUCTIONS



WARNING



ENSURE ALL WORKS ARE CARRIED OUT BY OR INSPECTED BY A CERTIFIED ELECTRICIAN

Step 1. Unplug the power source for the heating device and the G20.1 chiller

Step 2. Locate and cut the active wire to your heating device (see diagram to the right). Most active wires are brown or red but this should be double checked with an electrician.

Step 3. Divert the active wire into the blade connects (terminals 4 and 5 shown below)

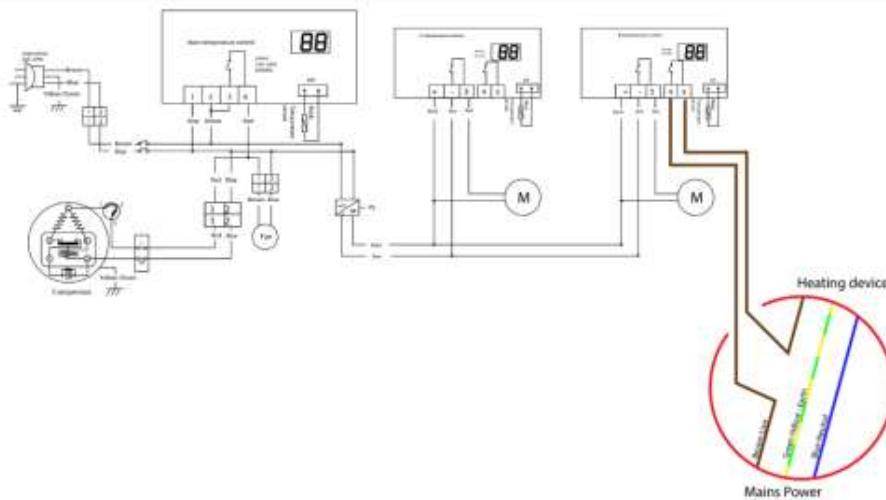
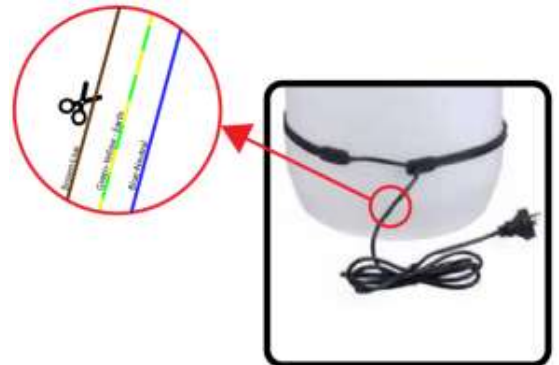

Step 4. Plug both the G20 and heating device into mains power

NOTE: This is the same process for Controller A and Control B. So repeat this step to wire multiple controllers in the same way.